

INO MACHINERY AS 534 – RADIAL DOUBLE MITRE SAW – 600 mm.

INO MAKINE AS 534/65	RADIAL DOUBLE MITRE SAW CUSTOMIZED FOR ALUMINIUM PROFILES
---------------------------------	--

Net cutting length of 6.500 mm.
Cutting section in 45 degrees: 151 X 410 mm.
Cutting section in 90 degrees: 200 X 380 mm.

Huge cutting section thanks to the radial moving sawblade
Sawblade diameter 600 mm. / 4,0 kW 2.800 rpm motors
The rack basis + the linear guides basis are machined, the rack mill and the linear guides connection holes are drilled&tapped with 5 Axis Metal Processing Center. Electrostatic Powder Coated Painting.
10" HMI TouchPanel for the user interface.
Mitsubishi PLC + Mitsubishi CClink servo Motors + Drivers with absolute encoders.
Movable head is moving on rack and pinion + linear guides.
The angular accuracy: 0,1 degree.
The cutting accuracy: 0,1 mm.
Pulse spray mist coolant system
Cutting heads tilting 45-90 degrees pneumatically through a cylinder and inbetween angles are adjusted manually
Automatic cutting with a receipt prepared by the operator.
Hydro-Pneumatic feeding of the cutting saws.
1.5 meter supporting roller conveyor connected on the movable head.
Protection covers moving up and down automatically
2 pieces of horizontal and 1 piece vertical clamping pistons for each head.
Colored cables inside the electrical cabinet.
Sawblades: Wemaro
CE Certificate and test reports.
Users' manual.

OPTIONAL	Mechanical profile supports in the middle of the machine. 4 pieces.
OPTIONAL	Step-by-step automatic cutting in 90 degrees
OPTIONAL	Oversize cutting support for cuts up to 10 meter.
OPTIONAL	Label printer.
OPTIONAL	Data transfer from window production softwares like Chakal, ReynaPRO, Schücal or Orgadata Logikal.

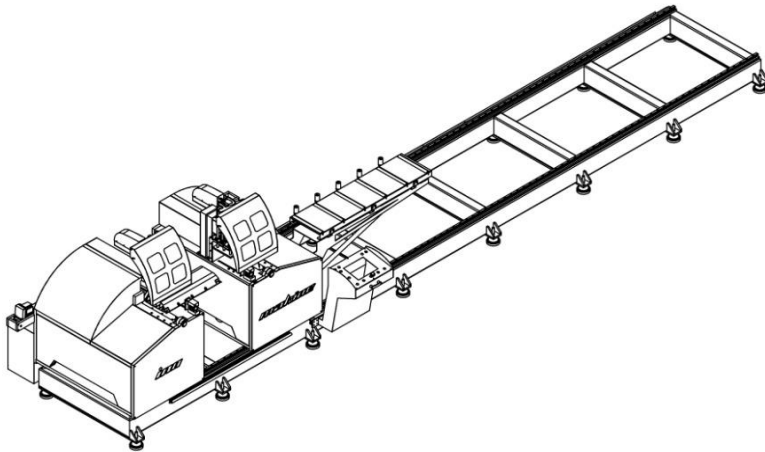
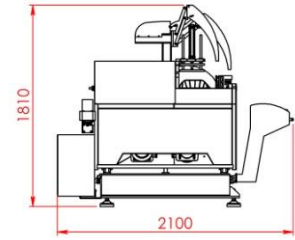
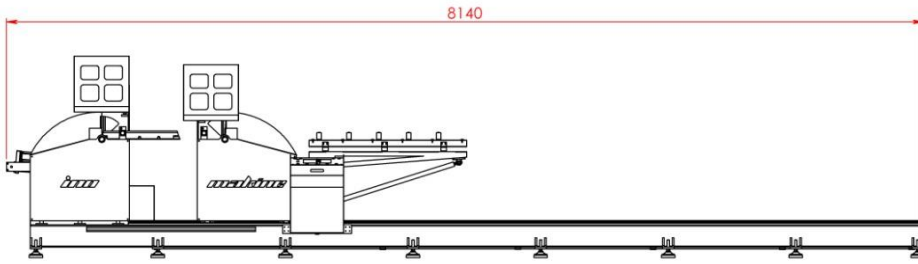

3700 kg

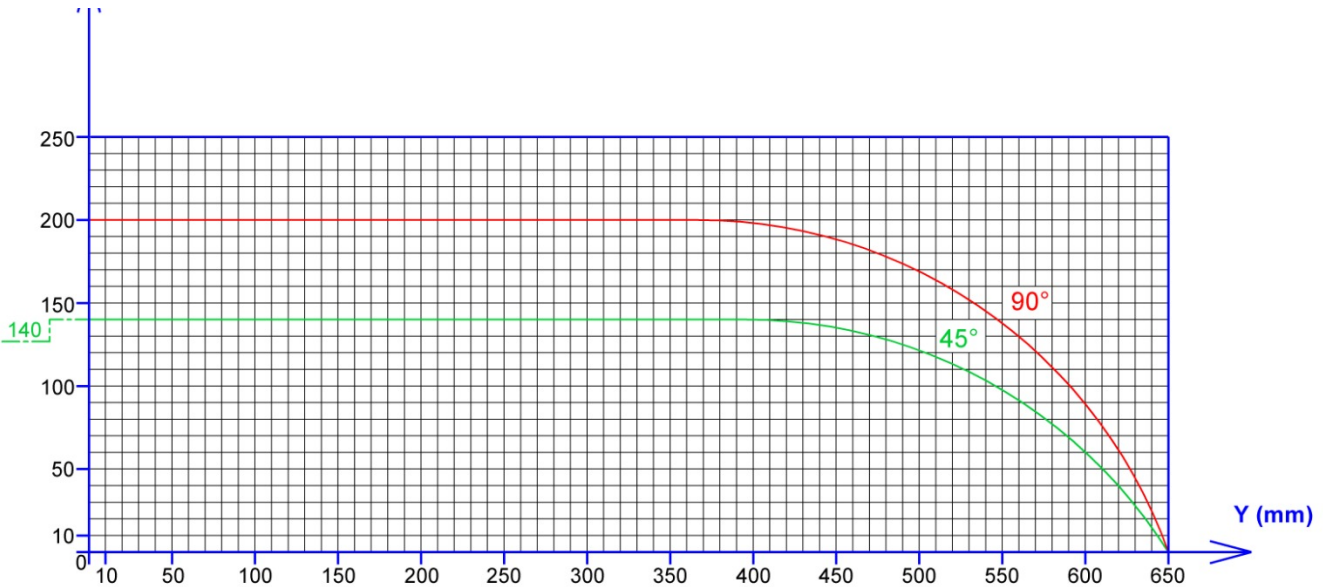

AS-534 / 65 (Ø 600)

CUTTING HEIGHT IN 45 DEGREES CAN BE ADJUSTED TO 155 mm.



